

IGHEM 98  
Acoustic Flowmeters in Circular Pipes: Acoustic Transducer and Conduit Protrusion  
Effects in Discharge Measurement

by  
Francis Lowell  
Technical Director Accusonic Technologies

Steve Schaefer  
Metropolitan Water District Southern California

Jim Walsh  
Sr. Engineer Accusonic Technologies

**Abstract**

This paper presents field data, laboratory data and computational fluid dynamic (CFD) modeling of the effect of acoustic transducer protrusion and internal conduit on acoustic flowmeter accuracy. Tests at a plant in southern California, where relatively good hydraulic conditions exist, indicated that the discharge measurements using two types of transducers were reading differently. Initially, the discharge readings based on internal mounted acoustic transducers indicated that a turbine was not meeting efficiency requirements. A second test was performed using “feed-thru” mounted transducers located upstream of the original transducers indicated a lower discharge. CFD investigations and laboratory tests of the flow disturbances caused by both transducer types show that the errors caused by transducer protrusion are small. CFD simulations of several internal conduit configurations and locations show that the conduit caused the discharge measurement to read high. Based on these investigations, new guidelines for installing internally mounted transducers and conduit have been adopted.

The results of the lab tests also indicated that the velocity based on externally mounted (feed-thru) types of transducers tend to be slightly low in small pipe diameters (<1 meter). The authors will present these findings and present new installation guidelines.

**Background**

The Etiwanda Power Plant, located in Southern California, is used to recover energy in the water distribution system owned and operated by the Metropolitan Water District of Southern California (MWD). The power plant (25 MW Pelton unit) was installed and tested in 1994. Initial field performance test indicated the turbine did not meet performance guarantees. The turbine flowrates were being measured with an Accusonic Model 7400 flow console with Model 7630 internally mounted transducers (8 path cross plane configuration) installed in a 8 foot diameter penstock. The turbine manufacturer, Fuji Electric Company LTD., indicated that the internally mounted transducers produced a high flow reading of approximately 2% as described by Sugishita<sup>1</sup>. Since MWD had numerous other installations with internally mounted transducers and to attempt to resolve the turbine discharge measurement issue, the penstock was unearthed and a Accusonic Model 7601 feed-thru type

---

<sup>1</sup> K Sugishita, T. Mototki, T. Kosugi, *Correction method to improve the accuracy of multipath acoustic flowmeters* 16<sup>th</sup> symposium of the IAHR, Sao Palo Brazil September 1993

transducers (8 path cross plane configuration) was installed directly upstream (1.25 pipe diameters) of the existing meter. This arrangement would allow direct comparison between the 2 types of transducers. Fuji Electric and MWD agreed to abide by the feed-thru transducer meter readings. A 2.1% flow difference was observed between the discharge measurements of the Model 7601 and 7630 transducers resulting in Fuji Electric meeting efficiency guarantees. In an effort to find the discrepancy observed between the Accusonic Model 7601 feed-thru and 7630 internal mount transducer installations at Etiwanda, three experiments were performed:

- 1) Flow tests at Alden Research Labs (ARL)
- 2) Computer simulations of the flow streamlines in the vicinity of the transducers with axial conduit present
- 3) Computer simulations of the flow streamlines in the pipeline with circumferential conduit present

### **Summary of Results:**

The initial effort was to identify the "protrusion" effect which Accusonic believed, was caused by the Model 7630 internally mounted transducers used at Etiwanda. Computer simulations using the Etiwanda pipe size and transducers and laboratory (ARL) test data using model 7601 and 7630 transducers in a 3-foot diameter pipe convinced us that the protrusion errors of the 7630 (internally mounted) and 7601 (feed thru) are very small. This is supported by other data, particularly for the model 7601, both from the field and computer simulations by Voser<sup>2</sup>.

This is not to say that there is no "Sampling error"<sup>3</sup>. The Sampling error, which makes the path read high, is almost exactly compensated for by the flow deflected (disturbance effect) around and over the transducer, which makes the path read low. The "dead water" in the transducer "pocket", in the case of the 7630 transducer, also makes the path read low.

Because the initial computer simulations and ARL Lab test did not show errors large enough to account for the differences between installations that were measured at Etiwanda, we had additional CFD simulations run with the circumferential conduit modeled in the flow, without transducers. The effect of the conduit produced velocity measurement errors on the order of 2.2% high. When combined with the previous computer simulations of protrusion errors discussed below, this produced a total meter error of approximately 2.1%, which was remarkably close to the 2.1% observed during our tests at Etiwanda.

We are now recommending to our field personnel and customers that internally mounted transducer conduit be run downstream to a point at least 1 diameter from the center of the meter section before any circumferential conduit is installed.

### **Detailed Results of Tests and Simulations**

---

<sup>2</sup> A Voser *CFD Calculations of the protrusion effect and impact on the acoustic discharge measurement accuracy* 1<sup>st</sup> symposium of the IGHEM, Montreal Canada June 1996

<sup>3</sup> Sugishita, Op-cit

The paragraphs below summarize the tests performed by Accusonic Technologies at ARL, and refer to the simulations performed for us by Ricardo Airflow Sciences Corp. (Airflow). It should be noted that we have also collected a considerable amount of field test data of pumps and turbines that leads us to believe that the Model 7601 transducers used in the tests at Etiwanda introduce very small errors (<0.1%) in pipe sizes of 8 feet and above.

**Results of Tests at Alden Research Labs**

A 36" spoolpiece was constructed with a 4-path single plane of Model 7620 recessed transducers as a velocity reference. These transducers have no measurable protrusion effect. This same spoolpiece section had been previously calibrated against a 100,000 pound volumetric weigh tank at ARL Building 2. Approximately 6" downstream of each of these transducers, Model 7601 transducers were mounted at the exact elevations of the upper two acoustic paths. Similarly, internal mount transducers were mounted at the elevations of the lower two paths. There was no conduit inside the pipe, the wires from the 7630 were run a short distance downstream from the transducers and brought out through the pipe wall. (See Fig. 1.)

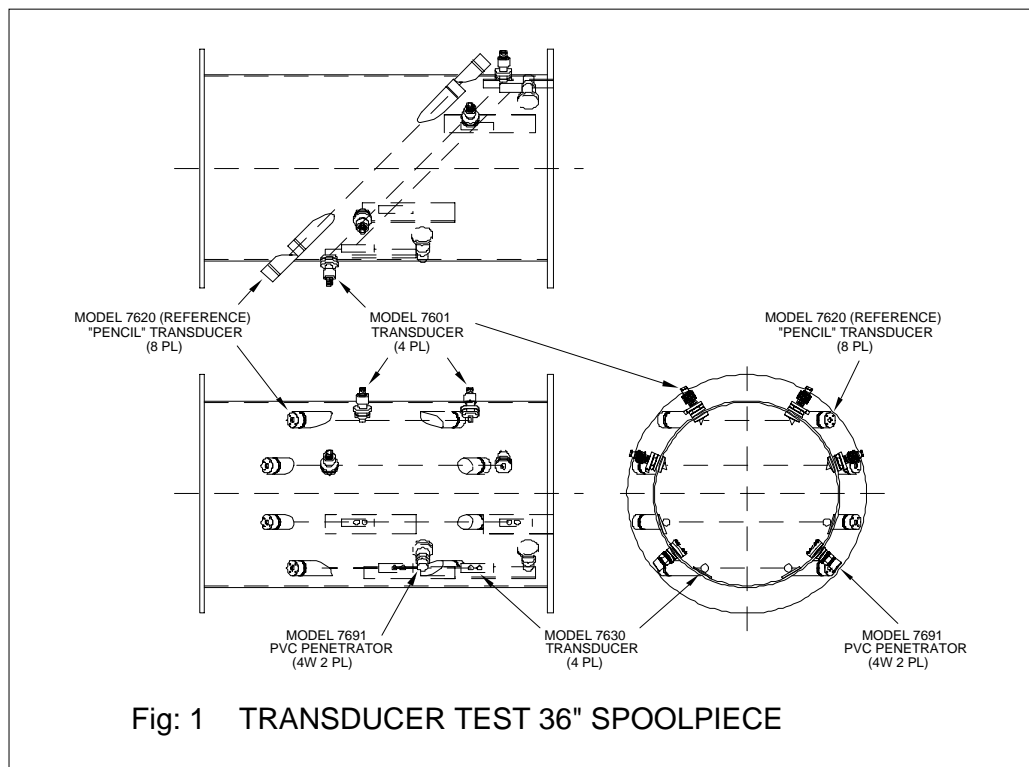

The spoolpiece was set up in Building 1, the "old" lab at ARL, with more than 10 diameters of straight pipe upstream and about 4 diameters downstream to a butterfly valve used to control the flow. Maximum flow was limited by the level in the supply pond, which introduced air into the water at the higher flowrates (90 CFS and above). Run 7 is omitted from these test runs because the excess air affected the operation of the acoustic flowmeter. The data in Table 1 is presented by calculating flow for the

upper half of the pipe using the 7620 recessed transducers (top flow) and comparing this to the flowrate based on the model 7601 transducers. Similarly, a flowrate for the lower half of the pipe was calculated based on model 7620 transducers and comparing this to the model 7630 transducers.

| Run                             | Reference<br>Flow CFS<br>(a) | 7620                   |                           | 7601                   | 7630                      | Bottom<br>Flow CFS<br>(e) | % delta<br>bottom<br>(e-c)/c |
|---------------------------------|------------------------------|------------------------|---------------------------|------------------------|---------------------------|---------------------------|------------------------------|
|                                 |                              | Top<br>Flow CFS<br>(b) | Bottom<br>Flow CFS<br>(c) | Top flow<br>CFS<br>(d) | % delta<br>top<br>(d-b)/b |                           |                              |
| 1u                              | 10.87                        | 10.70                  | 11.05                     | 10.63                  | -0.64                     | 11.11                     | 0.62                         |
| 1d                              | 10.90                        | 10.71                  | 11.09                     | 10.70                  | -0.08                     | 11.15                     | 0.50                         |
| 2d                              | 69.99                        | 68.14                  | 71.83                     | 67.87                  | -0.40                     | 72.08                     | 0.34                         |
| 2u                              | 70.17                        | 68.45                  | 71.82                     | 68.24                  | -0.31                     | 71.79                     | -0.04                        |
| 3d                              | 21.99                        | 21.36                  | 22.61                     | 21.35                  | -0.03                     | 22.67                     | 0.24                         |
| 3u                              | 21.99                        | 21.47                  | 22.52                     | 21.47                  | 0.00                      | 22.52                     | 0.03                         |
| 4d                              | 58.90                        | 57.43                  | 60.39                     | 57.35                  | -0.13                     | 59.43                     | -1.59                        |
| 4u                              | 59.08                        | 57.80                  | 60.36                     | 57.56                  | -0.42                     | 60.43                     | 0.12                         |
| 5d                              | 82.21                        | 80.32                  | 84.11                     | 79.95                  | -0.45                     | 84.20                     | 0.10                         |
| 5u                              | 82.03                        | 80.11                  | 83.92                     | 79.53                  | -0.72                     | 84.00                     | 0.10                         |
| 6d                              | 5.04                         | 4.90                   | 5.18                      | 4.95                   | 1.01                      | 5.19                      | 0.21                         |
| 6u                              | 5.06                         | 4.92                   | 5.20                      | 4.93                   | 0.16                      | 5.18                      | -0.44                        |
| 7                               |                              |                        |                           |                        |                           |                           |                              |
| 8d                              | 30.96                        | 30.15                  | 31.77                     | 30.18                  | 0.08                      | 31.85                     | 0.25                         |
| 8u                              | 30.97                        | 30.19                  | 31.76                     | 30.06                  | -0.43                     | 31.68                     | -0.23                        |
| 9d                              | 40.38                        | 39.26                  | 41.51                     | 39.33                  | 0.16                      | 41.46                     | -0.10                        |
| 9u                              | 40.43                        | 39.40                  | 41.47                     | 39.32                  | -0.21                     | 41.29                     | -0.43                        |
| 10d                             | 50.61                        | 49.37                  | 51.86                     | 49.18                  | -0.39                     | 51.92                     | 0.12                         |
| 10u                             | 50.57                        | 49.23                  | 51.91                     | 49.32                  | 0.17                      | 51.73                     | -0.35                        |
| Average - (not including run 7) |                              |                        |                           |                        | -0.12                     |                           | -0.11                        |

Table 1- Test data 36" spoolpiece

The results of this test, shown on Fig 2, and Table 1 is that the 7601's and 7630's have no statistically significant bias. The standard error of the mean for both sets of data, to the 95% confidence interval is 0.2% and 0.25 % for the model 7601 and 7630 transducers respectively. The sampling effect calculated by Sugishita for a 36 inch diameter pipe at ARL would be:

| Model | Outer | Inner | Combined | Percent |
|-------|-------|-------|----------|---------|
| 7630  | 0.961 | 0.977 | .972     | +2.8    |
| 7601  | 0.981 | 0.986 | .985     | +1.5    |

Table 2- Sugishita prediction in 36 inch pipe

At ARL, we can conclude that the sampling effect is approximately equal to the disturbance effect since we did not observe anything close to the Sugishita predicted offsets or biases. It is reasonable to assume that these errors would be even smaller in larger diameter pipes, as shown by the CFD simulations below and other calibration data.

### 36 Inch Pipe Test Data

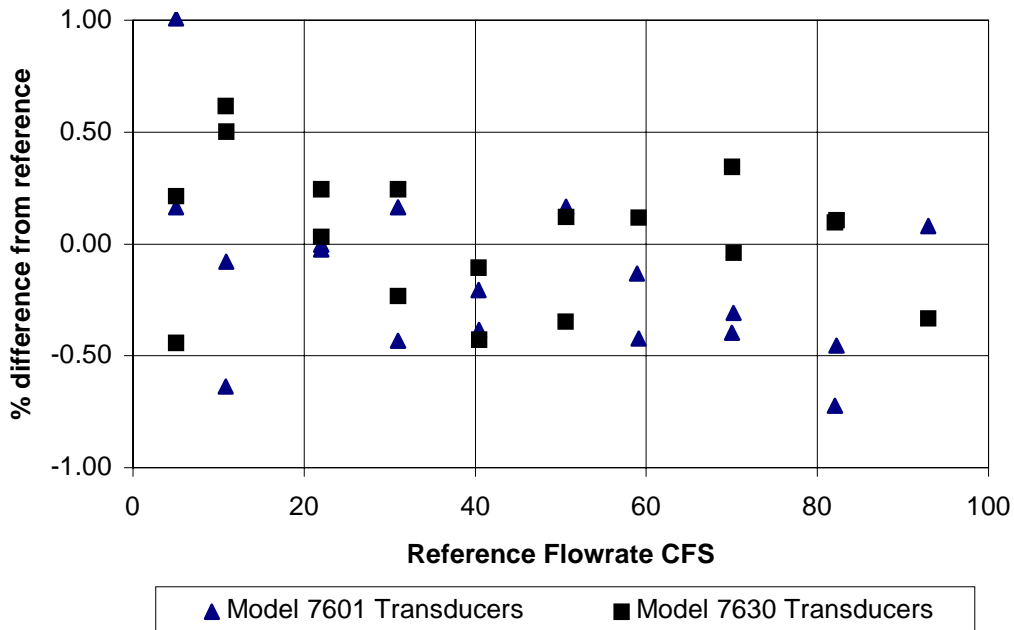

Figure 2 - error as function of flowrate

#### Transducer Simulations

Airflow Sciences Corp. was retained by Accusonic Technologies to perform computer simulations of the Model 7630 transducers installed in an 8 foot diameter pipe in order to model the Etiwanda installation. These simulations were run in all combinations of path and conduit locations, using an undisturbed velocity profile at a simulated Reynolds number of about  $10^8$  as a comparison and an input to the model.

The simulation was run in two phases to increase accuracy. The first was to simulate the flow (diametrical path) with the transducer in place in half the pipe, using a coarse "grid" to limit the computation time. A fine grid was then established around the transducer locations which used the coarse grid results as a boundary condition. This was done with flows going in both directions to simulate the 8 cases as shown in figure 3 and 4.

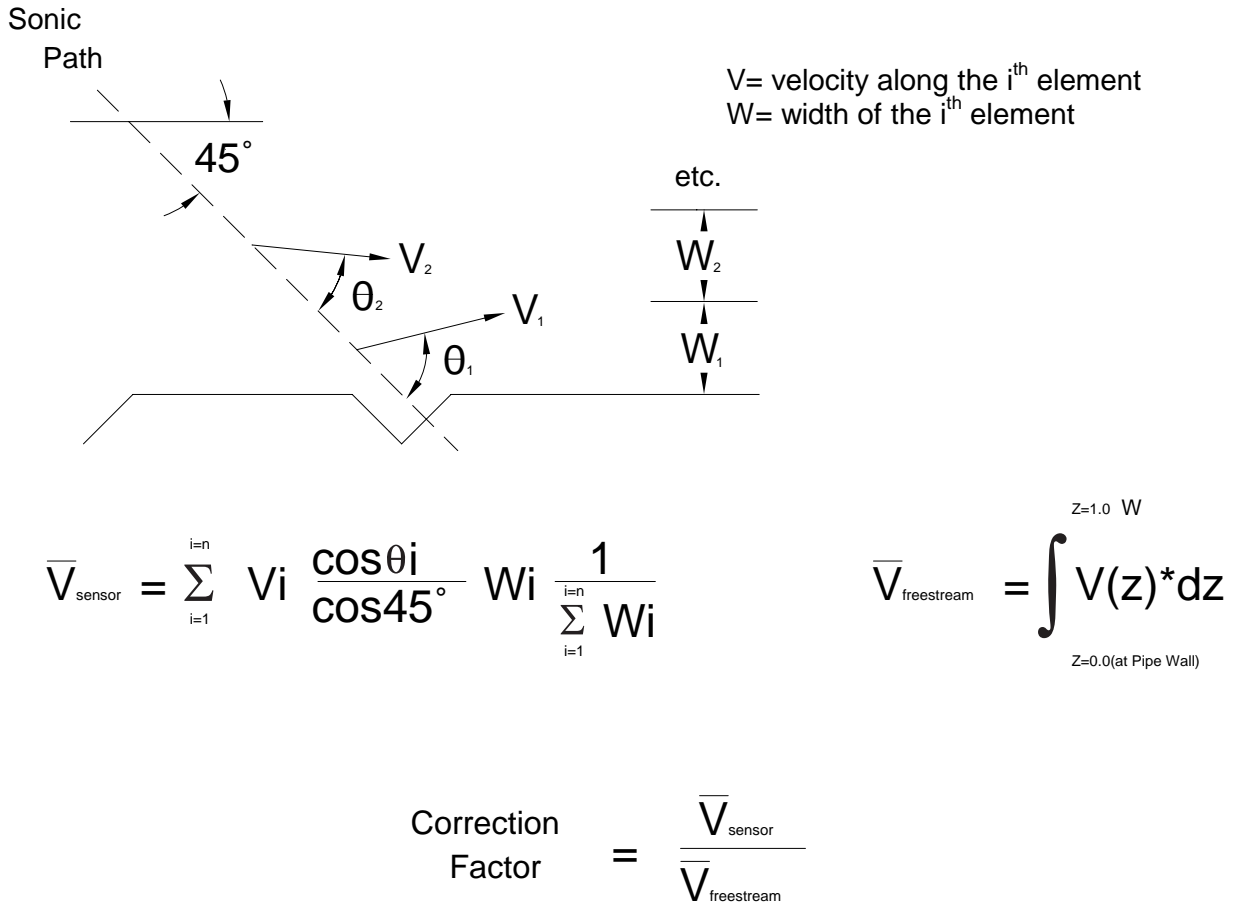

Figure 3 - correction factor

The velocity seen by each 45° path was modeled after determining the total velocity field. The correction factor is the ratio of the spatially averaged free stream velocity to the spatially averaged acoustic path velocity as shown in figure 3. Eight cases were modeled which include two transducer elements; two directions of flow over the transducer body; and two directions of the acoustic paths (+/-45°) relative to the body. These cases are referred to by number and are illustrated with Figure 4.

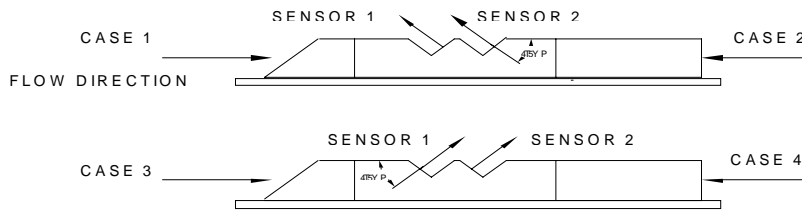

Figure 4 - Definition of flow direction and orientation cases 1 -4

The result of these simulations was a set of error curves, which show that the deflection and velocity errors are confined to well within a foot of the pipe wall (1.4 ft of path length), and that the integrated error in this layer for each transducer is on the order of 0.3% to 1.6%. A typical output is illustrated in Figure 5. To obtain the error for the total acoustic path length, each simulation result must be combined with the opposite transducer which forms the total path. The errors are then scaled by the total path length. Table 3 lists the errors for each case.

### Case 1 Simulation Results Velocity Profile Along Acoustic Path Vs. Freestream Velocity Profile

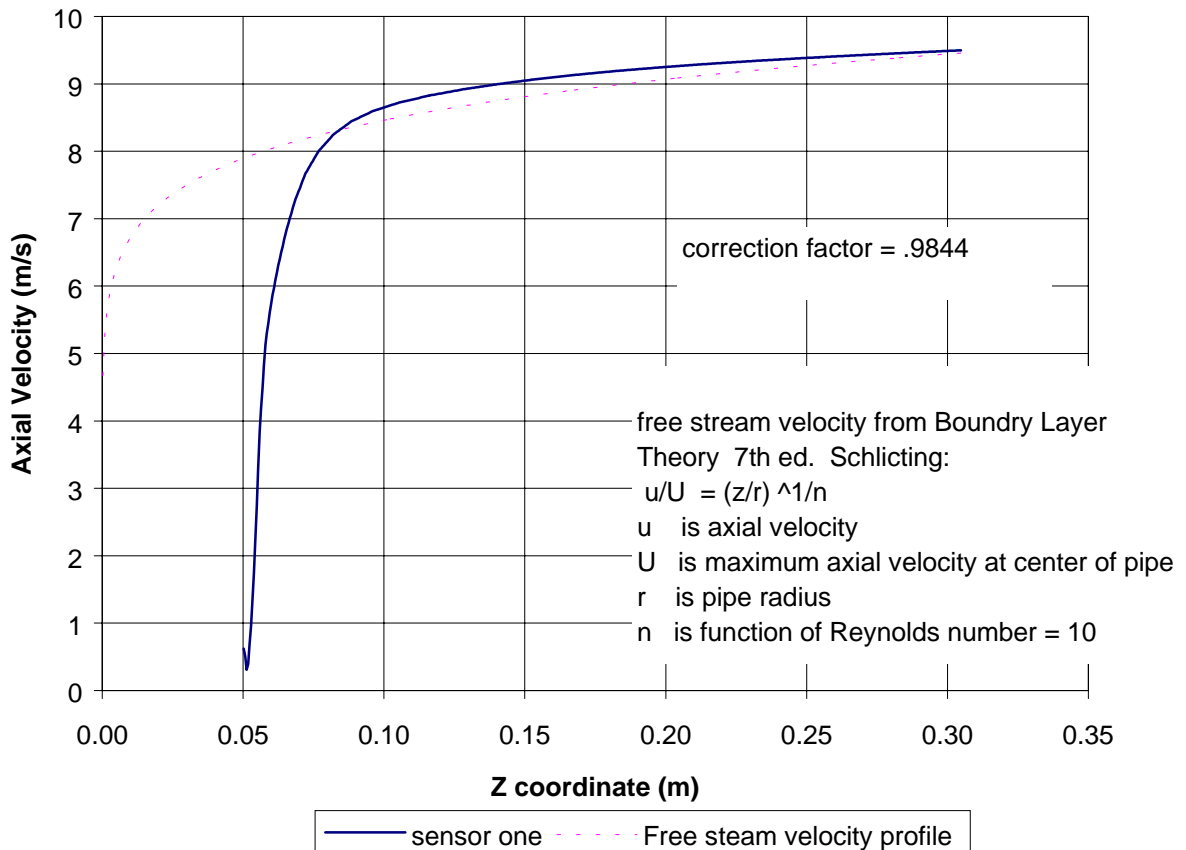

Figure 5 typical CFD run for Model 7630 transducers

| Case | sensor<br>(element) | correction<br>factor | correction<br>factor<br>% |
|------|---------------------|----------------------|---------------------------|
| 1    | 1                   | .9844                | -1.56                     |
| 1    | 2                   | .9885                | -1.15                     |
| 2    | 1                   | .990                 | -1.00                     |
| 2    | 2                   | .9916                | -0.84                     |
| 3    | 1                   | 1.0123               | +1.23                     |
| 3    | 2                   | 1.0074               | +0.74                     |
| 4    | 1                   | 1.0071               | +0.71                     |
| 4    | 2                   | 1.0032               | +0.32                     |

Table 3 - summary of runs with out circumferencial conduit

At Etiwanda the acoustic path lengths are 6.5 and 10 feet. The above errors were calculated for 1.4 feet of acoustic path length. The configuration at Etiwanda were modeled by cases 1 and 3. During the field testing both sets of elements were used.

The total combined error for a 2.8 foot path becomes:

case 1 sensor 1 + case 3 sensor 1 is  $-1.56 + 1.23 = -.33\%$

case 1 sensor 2 + case 3 sensor 2 is  $-1.15 + 0.74 = -.41\%$

The Error for a 10 and 6.5 foot acoustic path lengths (Etiwanda) becomes:

$-.37\% * 2.8 / 10 = -.1\%$

$-.37\% * 2.8 / 6.5 = -.16\%$

To obtain a flowrate correction factor the paths are weighted and normalized:

Correction Factor =  $(0.568 / 0.785 * -.1) + (0.217 / 0.785 * -.16) = -.1\%$

At Alden Research Labs the "inner and outer" acoustic paths in the spool piece were 3.4 and 1.7 feet respectively. The acoustic path configuration at ARL were modeled by case 1 and 3. As above, the combined error for the conditions at ARL becomes -0.37 and -0.39 for sensors 1 and 2.

Adjusted for path length at ARL, the CFD predicted offsets become:

For the inner path:

$-0.38 * 2.8/3.4 = -0.32\%$

For the outer path:

$-0.38 * 2.8/1.7 = -0.63\%$

The flowrate correction factor becomes:

$(0.568 / 0.785 * -0.32) + (0.217 / 0.785 * -0.63) = -.41\%$

At ARL, the proximity of each transducer to each other may account for the discrepancy between the field test and the CFD simulation, however it is interesting to note that the bias is negative. Of course with greater path lengths which are common in larger penstocks the error approaches zero percent for model 7630 transducers.

The sampling effect calculated by Sugishita for a 96 inch diameter pipe (Etiwanda) is:

| Model | Outer acoustic path | Inner acoustic path | Combined ratio | Percent |
|-------|---------------------|---------------------|----------------|---------|
| 7630  | 0.980               | 0.989               | .986           | +1.39   |
| 7601  | 0.997               | 0.999               | .999           | +0.15   |

Table 4 - Sugishita calculations for 96 inch diameter penstock

The low predicted Sugishita errors on the model 7601 transducer were attributed to the unusual installation. The inside of the Etiwanda penstock had a one inch thick mortar lining which was tapered to the feedthru in the vicinity of each transducer. Therefore the faces of the model 7601 transducers were installed nearly flush with the mortar lining. The protrusions of the inner and outer transducers were only 3/32 and 1/4 of an inch respectively. Because of the observed 2.1% flowrate discrepancy between the meter sections, we were initially concerned that the difference could have been caused by the partially recessed 7601 transducers. Therefore, the transducers were reinstalled with spacers behind each feedthru to bring them out to the original internal surface of the pipe lining. There were no changes to the readings. Obviously then, the 2% discrepancy between the two different types of transducers was not explained by any sampling effect.

### **Conduit Simulations**

After reviewing the somewhat unexpected results from the first series of Airflow simulations, it was decided to model the conduit at Etiwanda. The Etiwanda installation is slightly unusual in that a circumferential run of conduit is installed near the center of the meter section, a design which at the time seemed to make perfect sense. However, there was a possibility that the presence of the 2 1/2" and 1 1/4" diameter conduit installed circumferential in the penstock could be affecting the flowmeter accuracy by deflecting the flow velocity vectors to more nearly parallel to the acoustic paths, and by increasing measured velocity due to the blockage effect of the conduit. This is shown in Figure 6.

### Etiwanda Flow Meter Layout 8 Ft. Diameter Pipe

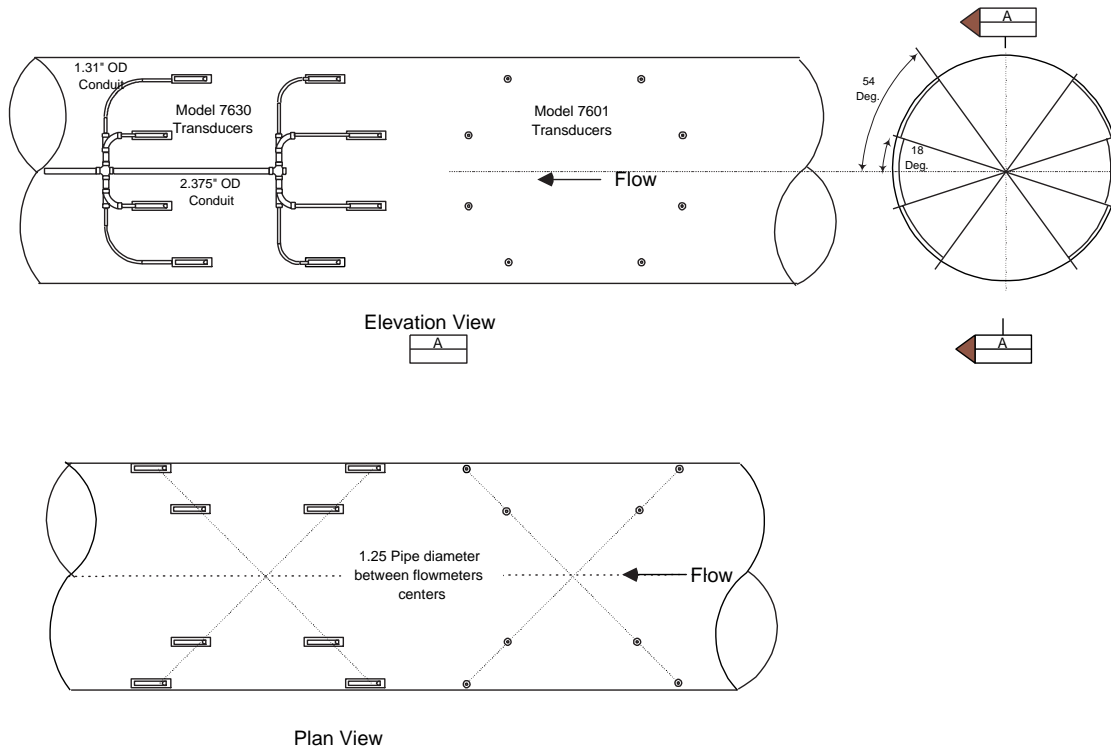

Figure 6 - conduit arrangement at Etiwanda

Using a slightly modified velocity profile with a smooth "top" instead of the cusp which the conventional<sup>4</sup> profile model produces, a series of simulations were run to determine the velocity profile in the meter section with and without conduit.

Three cases were run to determine the effect of conduit on the discharge measurement at Etiwanda. "Case 1" determined the effect of the conduit when located exactly in the center of the meter section. "Case 2" determined the influence the conduit made on the upstream transducers (at Etiwanda). "Case 3" determined the influence of the conduit on the downstream transducers (also at Etiwanda). Table 5 shows the result of these locations and determines the error in flowrate using the numerical integration constants as above.

| Condition    | Measured Velocity<br>m/s |            | Error From Ideal Velocity<br>% |            | Error in Flowrate<br>% |
|--------------|--------------------------|------------|--------------------------------|------------|------------------------|
|              | 18 ( inner)              | 54 (outer) | 18 ( inner)                    | 54 (outer) |                        |
| Unobstructed | 2.76                     | 2.486      | N/A                            | N/A        |                        |
| Case 1       | 2.789                    | 2.606      | 1.05                           | 4.83       | 2.1                    |
| Case 2       | 2.799                    | 2.626      | 1.41                           | 5.63       | 2.6                    |
| Case 3       | 2.743                    | 2.488      | -0.62                          | 0.08       | -0.4                   |

<sup>4</sup> Dr. Herman Schlichting, Boundary-Layer Theory (6<sup>th</sup> edition New York McGraw Hill 1968) p.581

The combination of Cases "1" and "2" yield a net error of 2.2 which is in line with the discrepancy observed in the field. Furthermore, the result also showed that when the conduit was in place at the center of the meter section, the flow as seen by the 45° crossed 4-path meter was significantly disturbed, producing a high reading of about 2.1%. This result is also in line with the field tests.

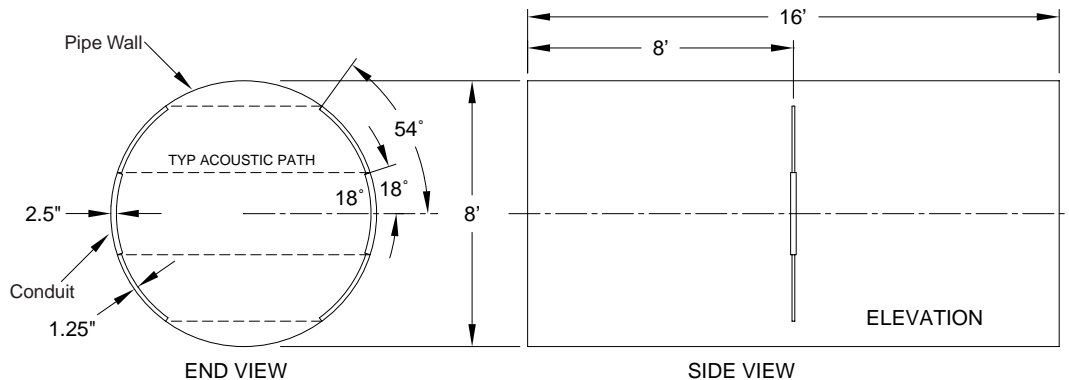

Model Flow Parameters:

Maximum Freestream Velocity ( $V_{max}$ ) 10 ft/s (3.048 m/s)  
 Pipe Diameter (D) 8 ft (2.438 m)

Fluid Properties: Water @ 25°C  
 Density ( $\rho$ ) 997 kg/m<sup>3</sup>  
 Viscosity ( $\mu$ ) 899.9x10<sup>-6</sup> Pa-s

Reynolds Number (Re) 7.2x10<sup>6</sup>

Proposed Inlet Velocity Profile (Based Upon Method of Schlichting with Adjustment)

$$V(y) = K_1 V_{max} (y/R)^{1/n} \quad \text{for } 0 \leq y/R \leq 0.8$$

$$V(y) = V_{max} k (y/R-1)^2 \quad \text{for } 0.8 \leq y/R \leq 1.0$$

$$k_1 = n/(n+0.125) 0.8^{-1/n}$$

$$k_2 = -3.125/(n+0.125)$$

$$n @ 10.5$$

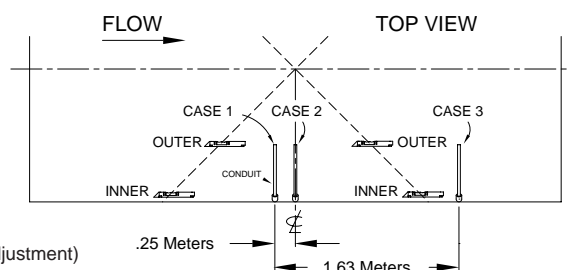

Figure 7 - conduit runs and simulations for general cases and Etiwanda

Airflow also did two runs with conduit located downstream of the downstream transducers, to simulate the effects of relocated conduit. With the conduit about 1/2 diameter downstream of the "inner" (+/-18°) path transducers, and one foot upstream of this location, the effects are negligible.

When the conduit error is combined with the transducer protrusion error (-0.1%) the net error becomes 2.1 percent which is exactly what was observed in the field. Figure 8 contrasts the Etiwanda case with proper conduit placement when circumferential runs of conduit are placed at least one diameter downstream of the meter section. If the Acoustic flow meter is placed in a pump storage scheme the location of the circumferential conduit should be placed a minimum of 2 diameters away from the center of the meter section.

### **Conclusions:**

Based on all the field test, lab test and CFD simulation data, we have obtained to date, we now believe that if conduit is installed with the circumferential runs located at least one diameter downstream of the meter section, internally mounted transducer/conduit protrusion errors are minimal.

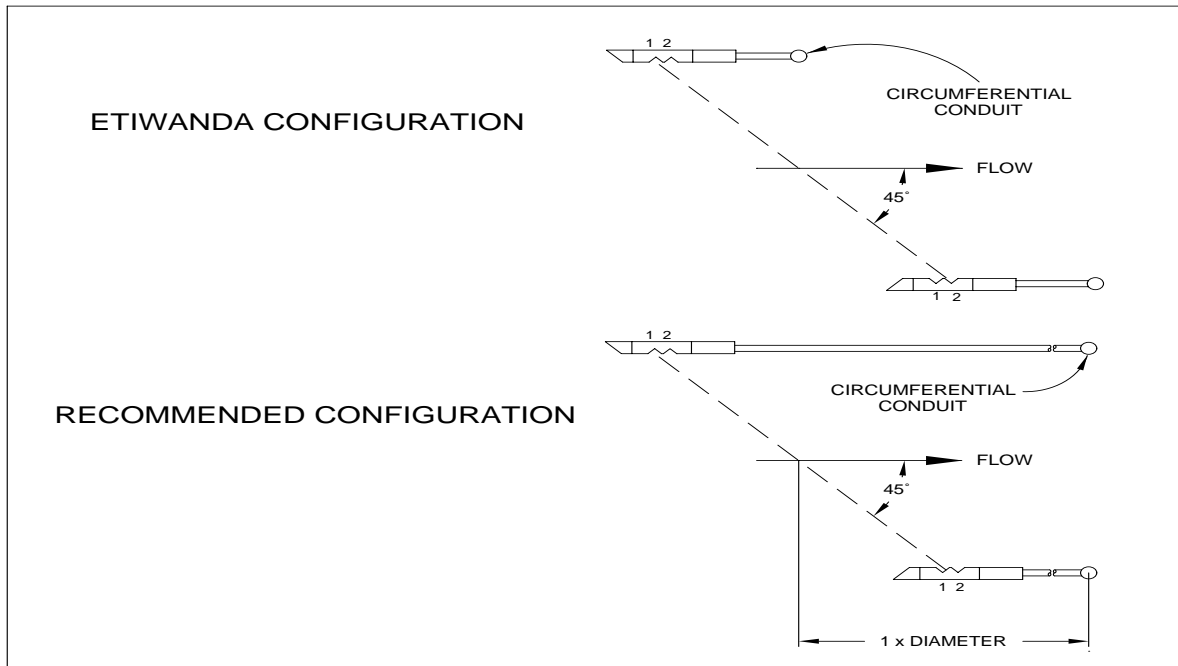

Figure 8 - illustrating proper conduit placement

Significant errors are caused by the combined effects of any conduit which is run in a circumferential direction around the inside of the pipe in the meter section, as is the case at Etiwanda.

At the present time we believe that the effects we have observed and modeled are linear with pipe size. The same transducers and conduit configuration in a larger or smaller pipe will have errors which are inversely proportional to pipe size.

At Alden and in the 96 inch diameter section at Etiwanda the Sugishita formula does not accurately predict the observed differences. This is because the flow disturbance effect is ignored in the calculation. Efforts should also be made to further quantify the protrusion error by repeating the flow simulations that take into account the close upstream-downstream proximity of the transducers to each other as occurs in crossed path installations in small diameter pipelines. As an alternative, the Lab test should be repeated in a larger diameter pipe so comparisons can be made with the current cases as outlined in Table 2. At this time we believe the protrusion error for model 7601 transducers is less than one quarter of a percent for pipe sizes in the 1 to 3 meter range. For pipe sizes greater than 3 meters we consider the error to be negligible.