

THERMODYNAMIC METHOD : COMPARISON OF SEA BIRD AND Pt 100 TEMPERATURE PROBES

E. PAQUET

E.D.F. Division Technique Générale

37, rue Diderot - BP 41 - 38040 GRENOBLE CEDEX - France

Tel: 33 4 76 20 89 36 Fax: 33 4 76 20 88 13 E.mail: emmanuel.paquet@edfgdf.fr

1. INTRODUCTION

Our team has been using the thermodynamic method for nearly 40 years. Since 1982 temperature difference at the terminals of hydraulic machines has been measured using Pt 100 type temperature probes combined with an ASL F17 thermometric measurement bridge. In 1995 we acquired Sea Bird probes which we have integrated in our measuring chain.

This paper describes the measures taken to implement these probes, and presents a comparison between the calibration performed by Sea Bird Electronics and a calibration by a national metrology laboratory. This is followed by a presentation of two comparative efficiency measurements.

2. CALIBRATING THE SEA BIRD PROBES

2.1 Calibration

Four SBE 3/S type probes, acquired in December 1995, were calibrated by the National Test Laboratory which is one of the five laboratories of the National Metrology Department. Its calibration services have been awarded a COFRAC (French Accreditation Committee) accreditation which is equivalent to a certain number of foreign accreditations (Italian, Swiss, British,...).

The probes were calibrated in comparison with plate resistor equipped standard thermometers immersed in a bath of melting ice (one point at 0°C), then in a characterised circulation bath (nine points from 5 to 20°C). The uncertainty (2σ) at the various calibration points is 7 mK.

At each calibration point, the reference temperature was compared with the temperature obtained from the Sea Bird calibration laws. The maximum difference observed at 0°C is 1.3 mK (at least 0.6 mK). The average difference for the 10 reference points is at most 1.4 mK (at least 0.2 mK).

Operators emphasised the outstanding repeatability of the SBE 3 probes.

The differences observed are completely integrated in the calibration uncertainty. The shape of the Sea Bird sensors did not allow calibration in a

triple water point cell where uncertainty could have been reduced to 4 mK (for the 0°C point).

This comparison proved that the calibration carried out by Sea Bird Electronics was perfectly compatible with the calibration carried out in France by an accredited laboratory, thereby justifying use of this calibration for controlled quality measurements.

2.2 On site check

Before and after testing, the Sea Bird probes are placed in a copper holder immersed in an isothermal container. This holder, designed like a thermal equalisation block, brings the live parts of the various probes as close to one another as possible in order to ensure that they measure the same temperature (figures 1 and 2).

The difference between the temperature measured on each probe and the average measurement of all four probes is normally less than 1 mK.

This test is designed to check probe integrity before and after testing.



Figure 1 - Temperature equalisation block - View from above

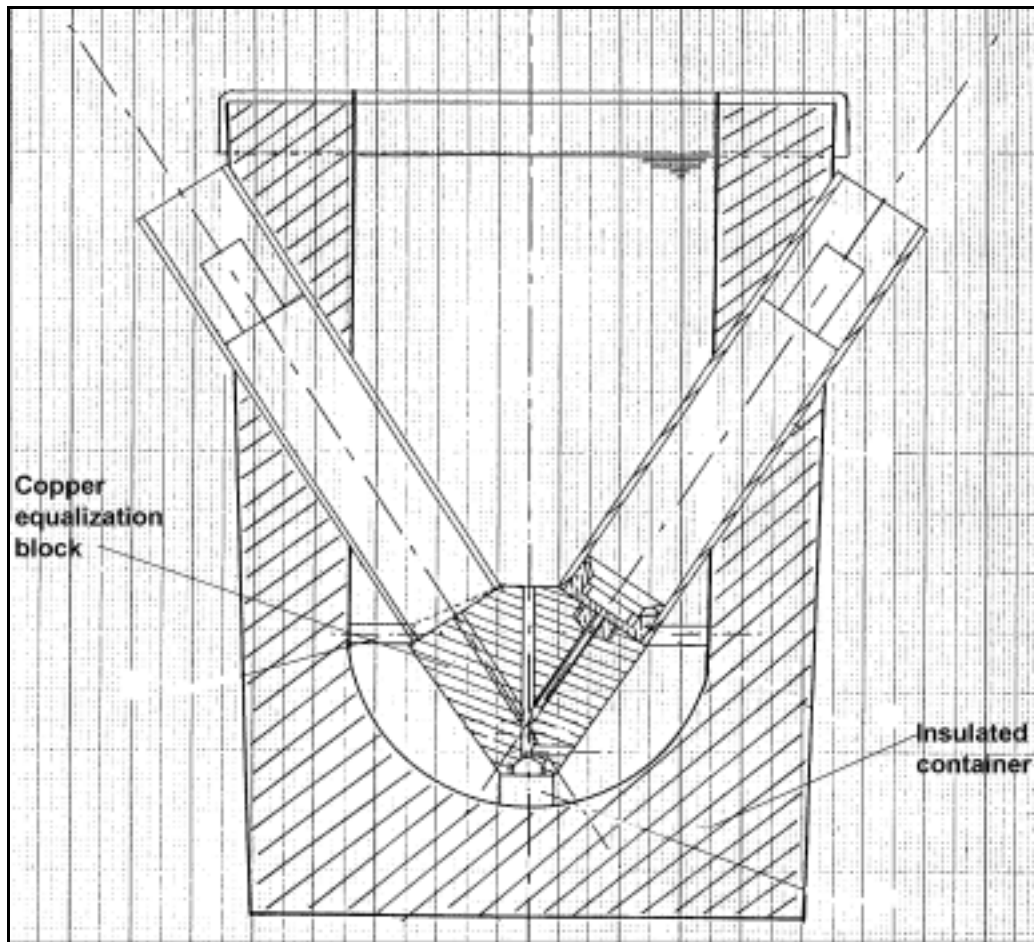

Figure 2 - Temperature equalisation block - Cross-section

3. TEST FACILITIES

Our complete measuring chain is structured around a PC and an HP 75000 acquisition unit for all voltage and current measurements. Data are collected by an GPIB link. Real time acquisition is managed by software that we have developed in Visual Basic. Measurements are analysed using a spreadsheet and specific macros.

3.1 Energy sensor

This sensor is designed to be mounted on the bosses of the Pt 100 probe energy sensor (most EDF turbines, on which the thermodynamic method is applicable, are equipped with them).

A motorised valve is placed between the boss and the energy sensor thus making it possible, among other functions, to take measurements using a partial expansion operating procedure by adjusting this valve from the measuring station.

This is illustrated in figure 3.

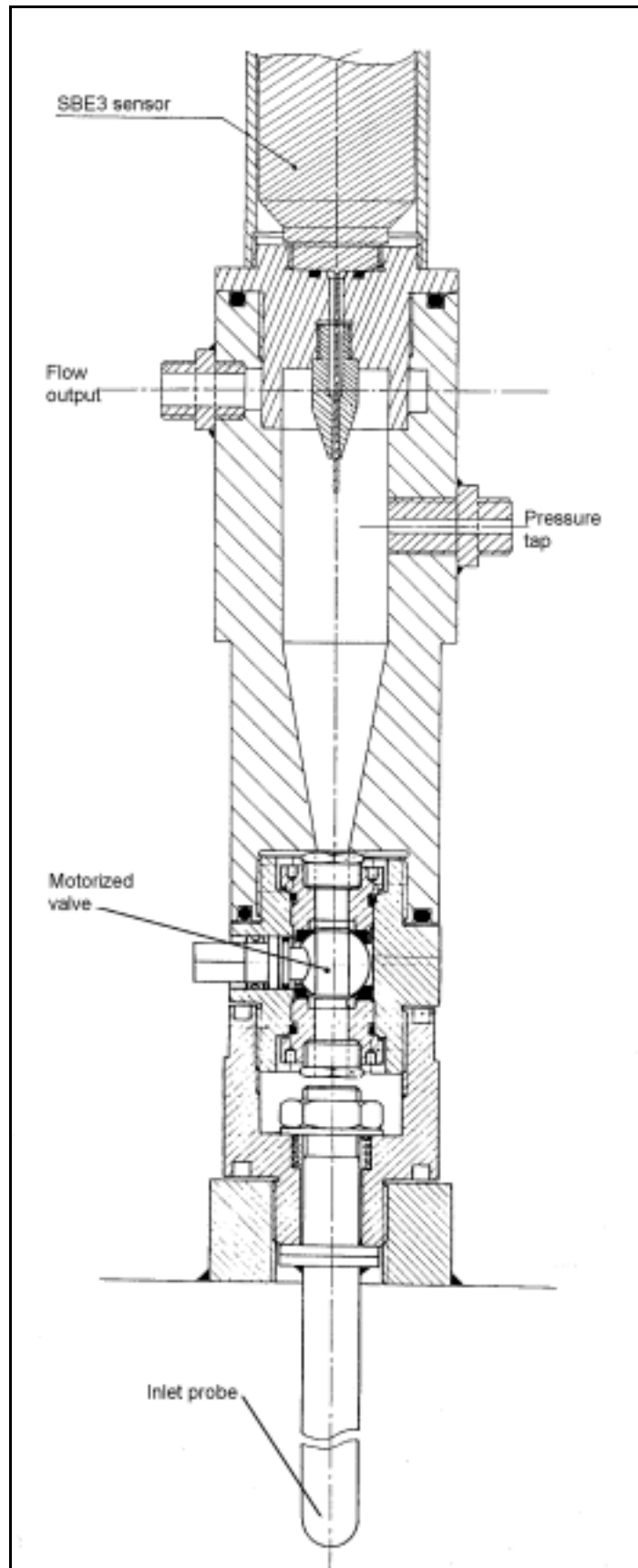

Figure 3 - Energy sensor - Cross-section

3.2 Downstream probe holder

The temperature probes placed at the outlet of the turbine draft tubes or in the tailraces are normally subjected to a great deal of stress (high speeds, turbulence).

A metal enclosure was designed in order to protect the probes from direct impact (figure 4). Furthermore, the increased weight of the assembly limits vibrations.



Figure 4 - Protection of the Sea Bird probes placed downstream of the turbines

4. **COMPARATIVE TESTS**

4.1 MIGOELOU power plant

This installation, located in the Pyrenees, contains two Pelton turbines driving $1.7 \text{ m}^3/\text{s}$ under a net head of 750 m, i.e. a power of approximately 10.5 MW per turbine.

Efficiency was measured using the « direct operating procedure » mode of the thermodynamic method (figure 5). The measurements were taken first with the Pt 100 probes and then with the Sea Bird probes.

Only the temperature measurement differed. The other phenomena (pressure, electrical power) were measured in the same way.

At maximum power, the temperature in the tailrace was measured at six points (figure 6). At the other operating points, only three points were measured.

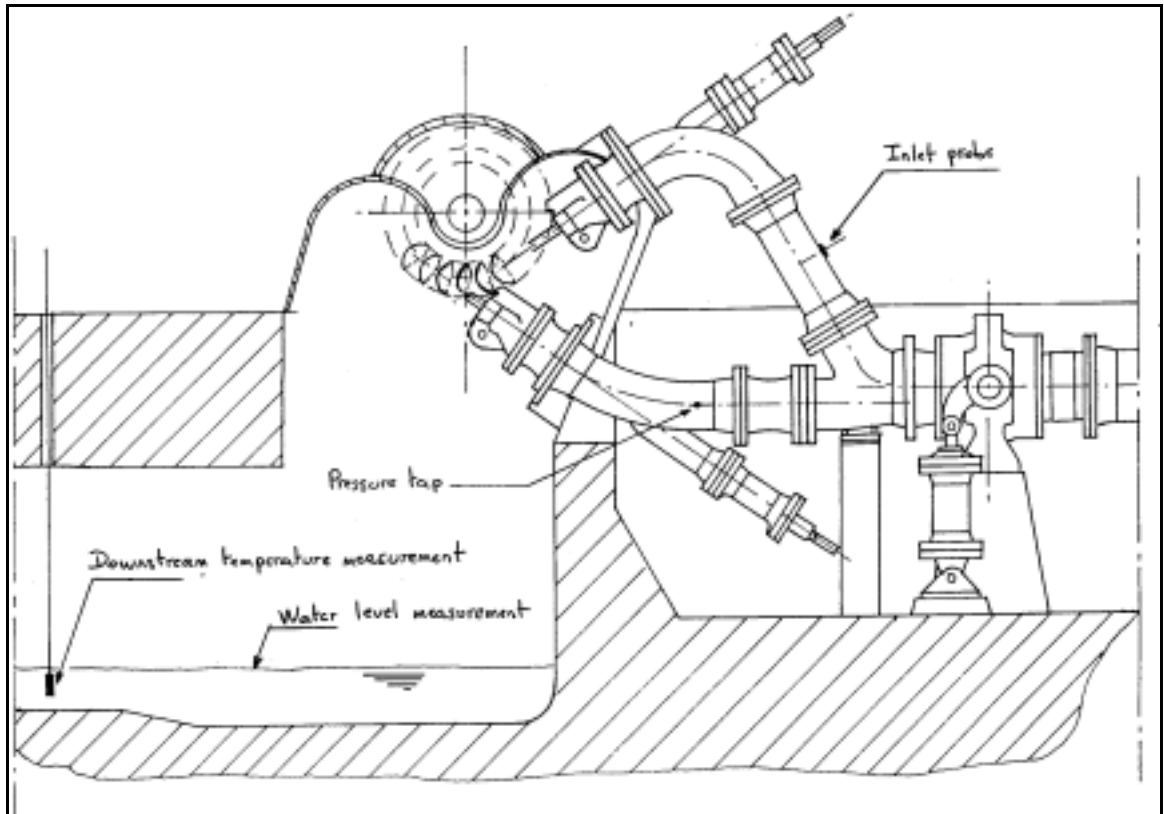

Figure 5 - Migoelou power plant - Measurement device

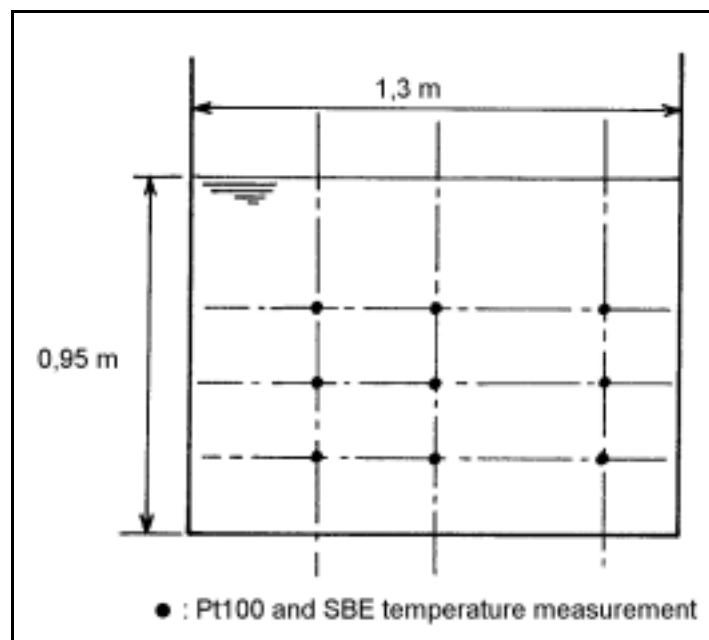

Figure 6 - Migoelou power plant - Temperature measurements in the tailrace

For the Pt 100 measurement, the relative uncertainty (2σ) on the efficiency measurement was calculated in detail. It equals $\pm 0.7\%$ of efficiency, i.e. $\pm 0.6\%$ for the maximum efficiency measurement of 84.6%.

The maximum difference in efficiency between the two measurement methods is 0.2%: the Sea Bird efficiency measurements are systematically smaller than the Pt 100 measurements (figure 7). This difference is virtually entirely ascribable to the temperature measurement: at maximum power, the temperature difference measured at the terminals of the machine is -251 mK for the Pt 100 probes and -257 mK for the Sea Bird probes, i.e. a difference of -6 mK.

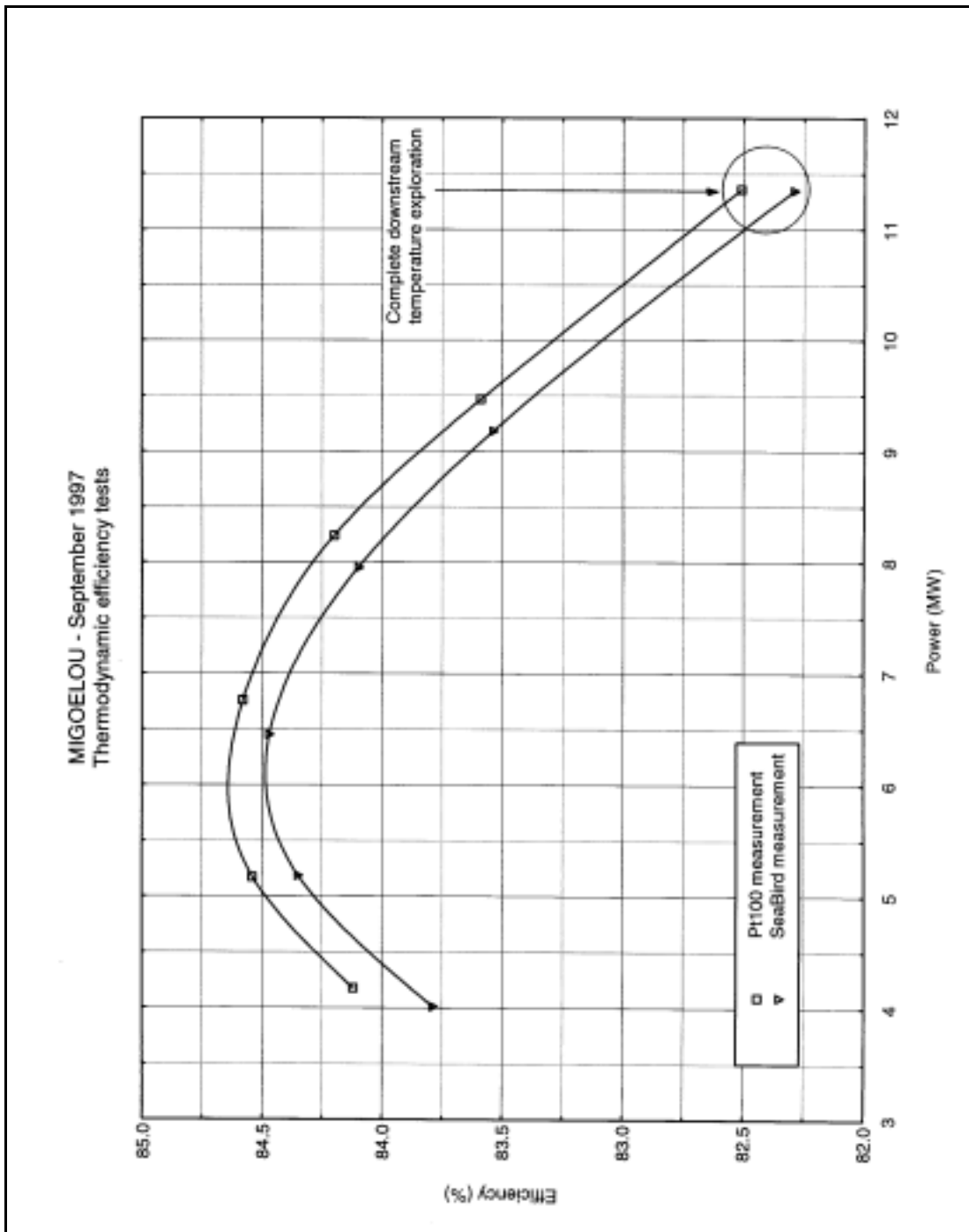

Figure 7 - Migoelou power plant - Efficiency measurements

4.2 The PEAGE DE VIZILLE power plant

This power plant, located near Grenoble in the French Alps, contains two 31 MW double Francis turbines driving 28 m³/s under a net head of 136 m (figure 8).

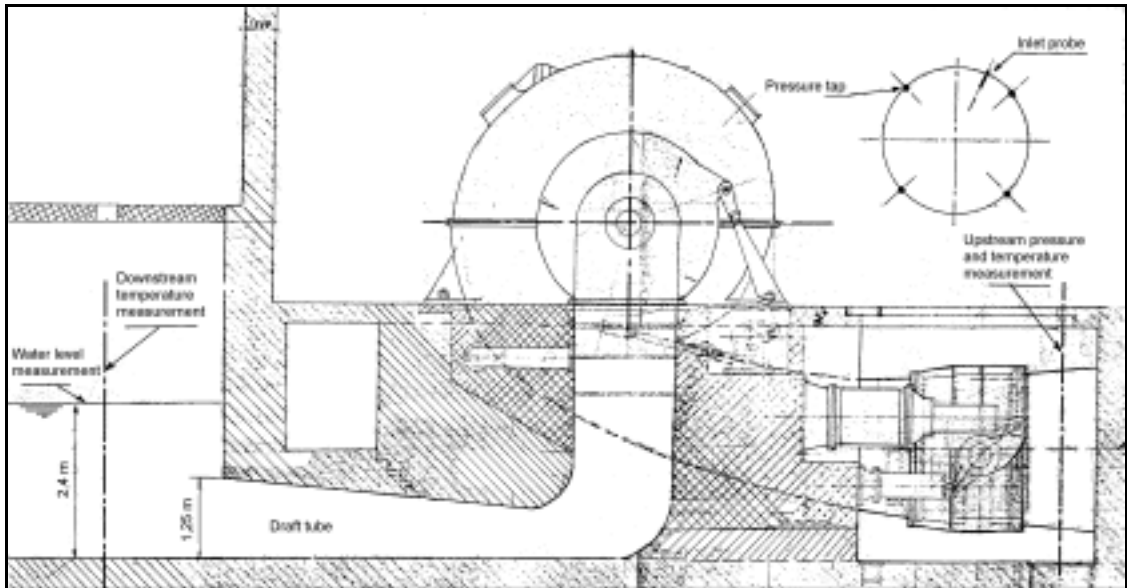

Figure 8 - Pégage de Vizille power plant - Measurement device

Just as for MIGOELOU, measurements were taken first with the Pt 100 and then with the Sea Bird probes. The temperature measurement points at the draft tube outlet are shown in figure 9. For the Pt 100, complete explorations were carried out at 21.5 and 30.7 MW.

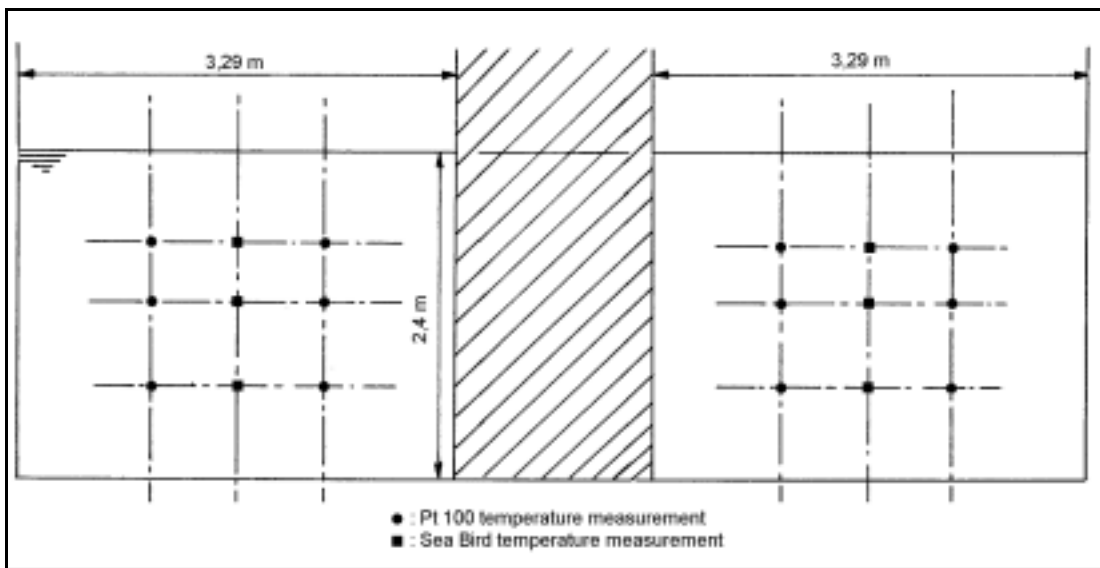

Figure 9 - Pégage de Vizille power plant
Temperature measurement at the draft tube outlet

For the Pt 100 measurement, the relative uncertainty (2σ) on the efficiency measurement equals $\pm 1.5\%$ of efficiency, i.e. $\pm 1.4\%$ for the maximum efficiency measurement of 90.8%.

The maximum difference in efficiency between the two measurement methods is 0.6%: the Sea Bird efficiency measurements are systematically smaller than the Pt 100 measurements (figure 10). Just as for MIGOELOU,

this difference is virtually entirely ascribable to the temperature measurement : at 30.7 MW, the temperature difference is -28 mK for the Pt 100 probes and - 31 mK for the Sea Bird probes, i.e. a difference of -3 mK.

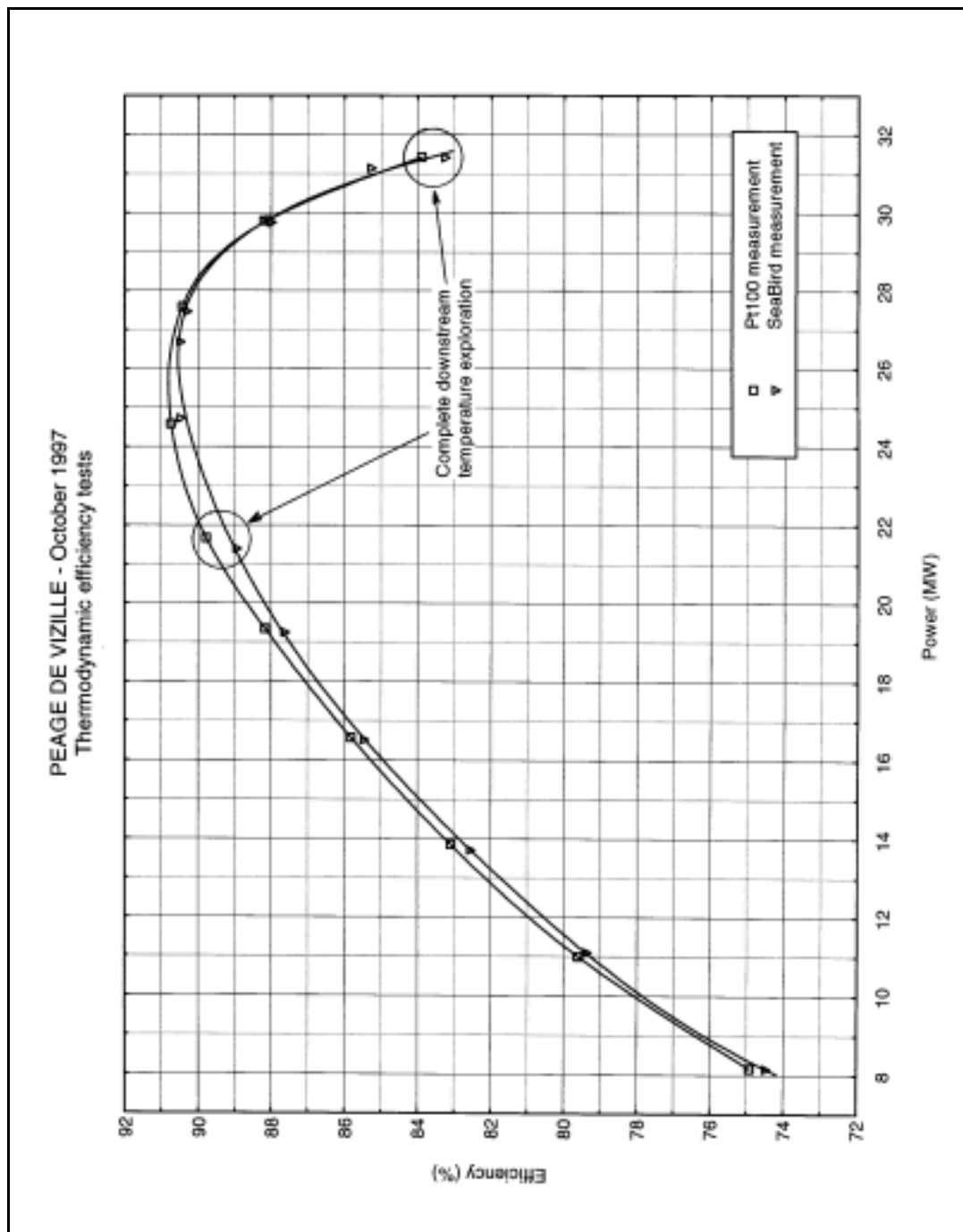

Figure 10 - Péage de Vizille power plant - Efficiency measurements

4.3 Analysis of the results

The differences measured are entirely integrated in the efficiency measurement uncertainty. The differences between the two methods are

mainly ascribable to the temperature difference measurement at the terminals of the machine. The heat transfers in the energy sensors were systematically measured and were identical for both sensors (Pt 100 and Sea Bird).

It is thus important to qualify the difference between the two temperature measurements in order to determine whether it is the result of disturbances linked to the site measurement environment (vibrations, electromagnetic disturbances) or of a bias directly linked to the measurement process.

Laboratory measurements are currently being performed in order to explain these differences as fully as possible.

5. CONCLUSION

The excellent metrological characteristics of the Sea Bird probes offer an undeniable advantage for their use in the thermodynamic method.

In the light of the results set forth in this document, we have decided to purchase additional Sea Bird probes in order to use them for measuring by means of the thermodynamic method.

However, as these probes are more space-consuming than the Pt 100, their position downstream of the turbines merits particular attention, particularly as they appear to have poor resistance to prolonged exposure to the vibrations generated by turbulence.

Nevertheless, the possibility of taking simultaneous temperature measurements on a large number of sensors allows quicker downstream temperature exploration than with probes requiring individual examination.

Consequently, the time required to study a correct holder for the downstream probes is often more than compensated by the time savings and increased accuracy resulting from the tests.