

Comparative measurements of velocity distributions with acoustic methods

Thomas Staubli, HTA Lucerne, Stefan Baumann, Rittmeyer AG

Abstract

Comparative flow field measurements in the inlet channel of a hydroelectric power plant were performed using an acoustic Doppler probe and an acoustic Doppler profiler. Measurements with a single probe, traversing the entire cross section, are very time consuming. On the other hand measurements with a velocity profiler demand little installation effort and can be performed within short time periods. This advantage, however, comes along with a higher measuring uncertainty. Qualitative comparison showed good agreement of the measured velocity distributions. The results matched also quantitatively well in case of good signal correlation and if erroneous data due to reflected acoustic signals are rejected.

1. Overview on acoustic methods

The acoustic transit time method is the most widespread and most accurate acoustic method for discharge measurement in hydraulic power plants. It can be used for open channel flow or closed conduit measurement. By measuring the times of the traverse of pulses sent in two directions, the average axial velocity \bar{v} of the fluid crossing the acoustic path of the pulse is determined.

Due to the fact that the difference of upstream and downstream transit time is measured, the accuracy of this method does not depend on the determination of the speed of sound.

Large scale turbulent structures cause flow field fluctuations at low frequencies. For that reason measurements must be done repeatedly and averaged. Multipath measurements lead to higher accuracy and faster convergence of the measurements. A detailed analysis of errors involved in this method is given by Voser, 1999.

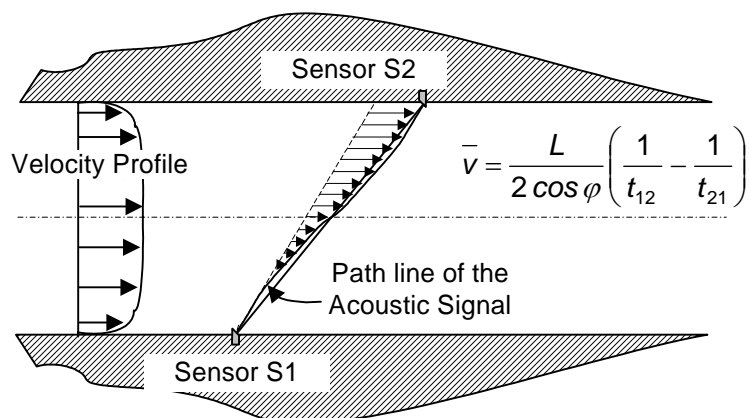

Figure 1. Acoustic transit time measurement

A second principle of acoustic measurement bases on the determination of the Doppler frequency shift of acoustic waves reflected by moving particles in flowing fluid. Frequency shifts of signals reflected from particles in large areas or entire conduit cross sections allow to determine averaged flow velocities or flow rates. If this method is used to measure a local velocity vector in a small sampling volume, one speaks of an acoustic Doppler velocimeter ADV.

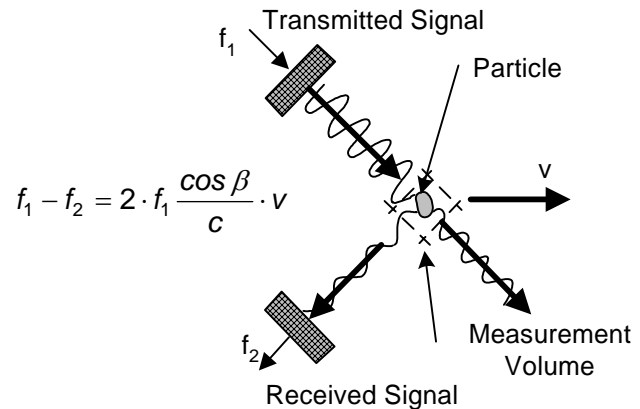

Figure 2. Acoustic Doppler velocimetry (ADV)

Such acoustic probes permit to measure local velocity vectors, if three receiving sensors are focusing on the same sampling volume at a given distance from the transmitter. Due to the small size of transmitter and receivers the flow is only disturbed to a minor degree by the presence of the probe. To correlate the Doppler frequency to flow velocities the speed of sound must be determined accurately. A minimum amount of particles must exist in the flow but otherwise signals are practically insensitive to water quality allowing a wide range of applications. An application of such probes for hydraulic measurements is described e.g. by Staubli, 2000.

If both, the travel time and Doppler frequency shift measurements are combined in one instrument it is possible to determine the distribution of projected velocities on an acoustic beam. Instruments based on this method are called acoustic Doppler profilers (ADP). With three acoustic beams oriented at different angles it is possible to evaluate the three components of velocity vectors assuming that the flow field is not varying much in the area covered by the acoustic beams.

The transmitter and receiver of the ADP are identical piezoelectric elements mounted in the instrument's head (see Figure 6). After a short transmit pulse is emitted from the transmitter, reflected signals scattered by small particles along the acoustic beam are measured by the receiver. The received signal is gated at different time intervals. With these time intervals and the speed of sound, cells along the acoustic beam are defined. The Doppler frequency shift is then evaluated in each cell being proportional to the projected flow velocities on the acoustic path. More details on this method are given by Gordon et al., 2001.

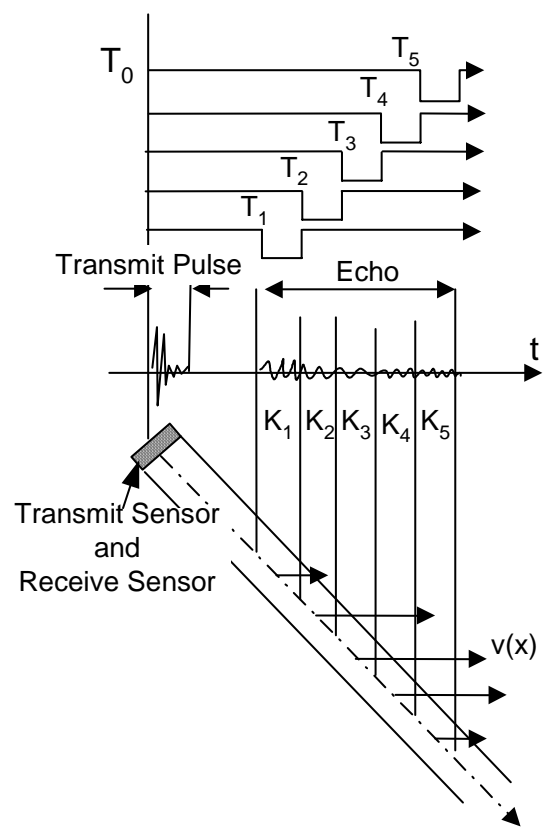

Figure 3. Acoustic Doppler Profiler (ADP)

In oceanographic measurements the so-called acoustic scintillation method is successfully used since some decades, Clifford 1983. Only in recent years progress was achieved with respect to hydraulic power plant measurement, Lemon 1996. The progress of this method is linked to the availability of faster digital signal processing possibilities. The signal processing of the scintillation method bases on the cross-correlation function determined from two parallel transmitted acoustic signals, as shown in Fig.4.

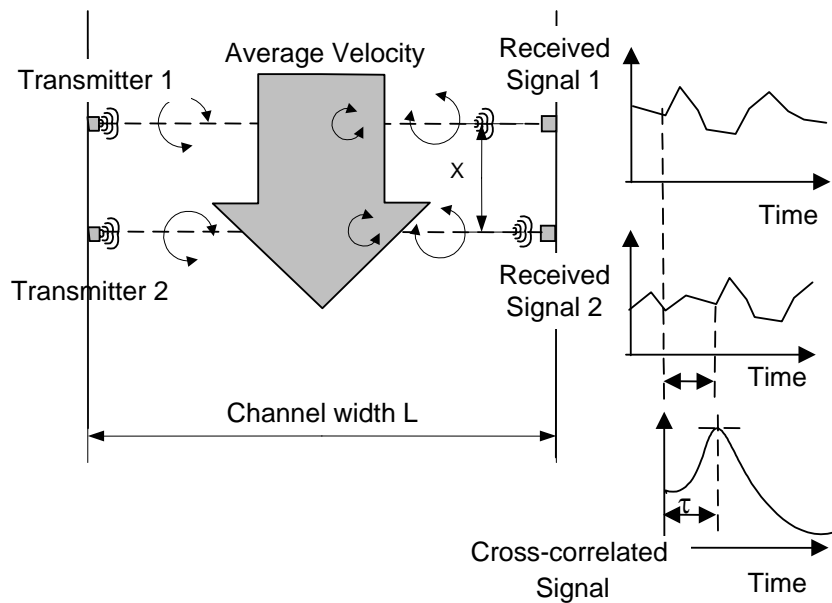

Figure 4. Scintillation method

Turbulent flows are characterized by vortical structures of varying size propagating with the flow. These structures effect a statistical variation of the refraction index in the flow field in time and space. Thus, acoustic waves travelling through such a flowing fluid are modulated in amplitude, phase and frequency by local turbulent flow structures. The mean flow velocity is related to the propagation time of such structures convection a given distance downstream. Of course, continuous vorticity formation and dissipation occurs decreasing the correlation of signals measured at different positions. Signals of very large and small scale turbulent structures will be either physically or electronically filtered assuring that the measured convection speed is representing the flow velocity. The schematic of this method is displayed in Figure 4. The time shift τ corresponding to the peak in the cross-correlation function calculated from signal 1 and 2 is a measure for the time delay of the flow structures.

2. Installation of measurements

From above described methods the acoustic Doppler velocimeter (ADV), Figures 2 and 5, and the acoustic Doppler profiler (ADP), Figures 3 and 6, were used for comparative measurements of velocity distributions at the inlet of the power plant Rathausen close to Lucerne. Probes were mounted on a hoisting device, as depicted on Figure 7, allowing to traverse the desired measuring cross section.

Velocity range 2.5 m/s
 Sampling rate of 25 Hz
 Acoustic frequency 10 MHz,
 Velocity resolution 0.1 mm/s
 Sampling volume 0.25 cm^3,
 (Nortec AS, Norway).

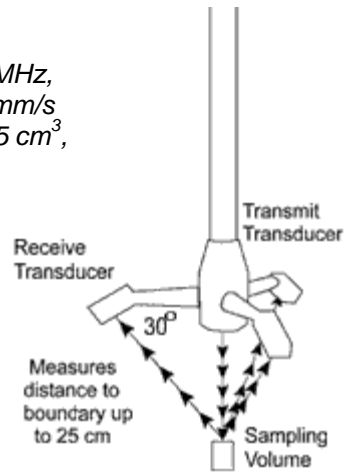
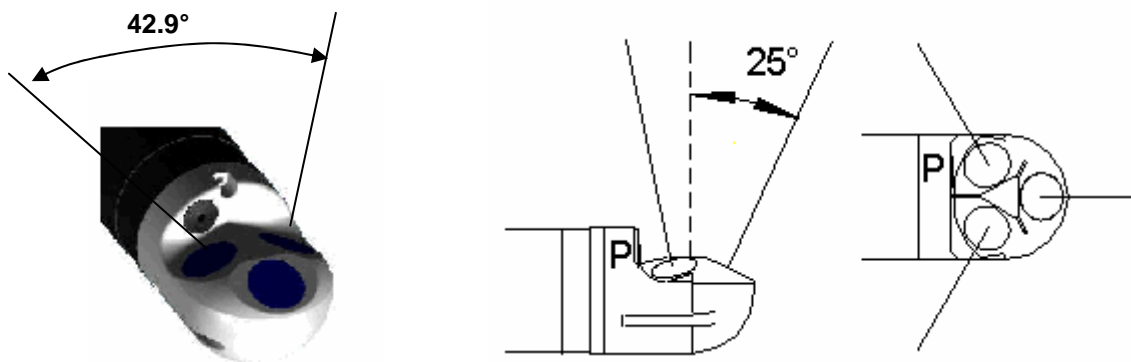

Figure 5. Acoustic Doppler velocimeter, ADV



Velocity range 2 m/s; Sampling rate of 1 Hz; Acoustic frequency 2 MHz; (Nortec AS, Norway)
 (Cell size 0.1 m and No. of cells 15 or 29 used in Rathausen).

Figure 6. Acoustic Doppler profiler, ADP

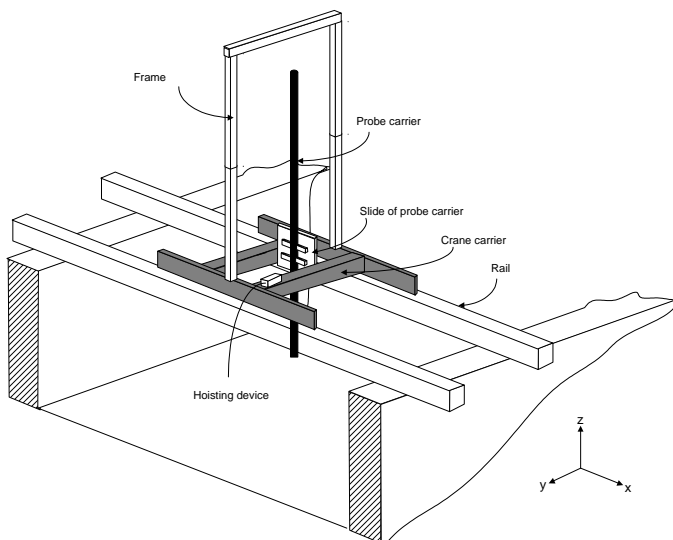

Figure 7. Setup of measurement

Of the two chosen measuring sections, the first section was 10 m upstream of the turbine trash rack at the location of the stop log slots, section B, and has a central pole in the stream, as shown on the photograph of Figure 7 or the schematic of Figure 8. The second section, A, was located 3 m upstream of the pole. The open channel has a total length of about 1500 m with a bent of 10 degrees, 25 m upstream of the pole.

The width of cross section A was 11.88 m and the depth 4.19 m. Whereas the width of cross section B was 5.5 m and the depth 3.69 m.

The grid of measuring points for the ADV probe consisted of 135 measuring points for section A and 99 measuring points for section B. For the ADP 15 vertical velocity profiles were measured in section A and 11 in section B. In addition 18 horizontal velocity profiles were measured with the ADP taking advantage of the stop log slots on each side.

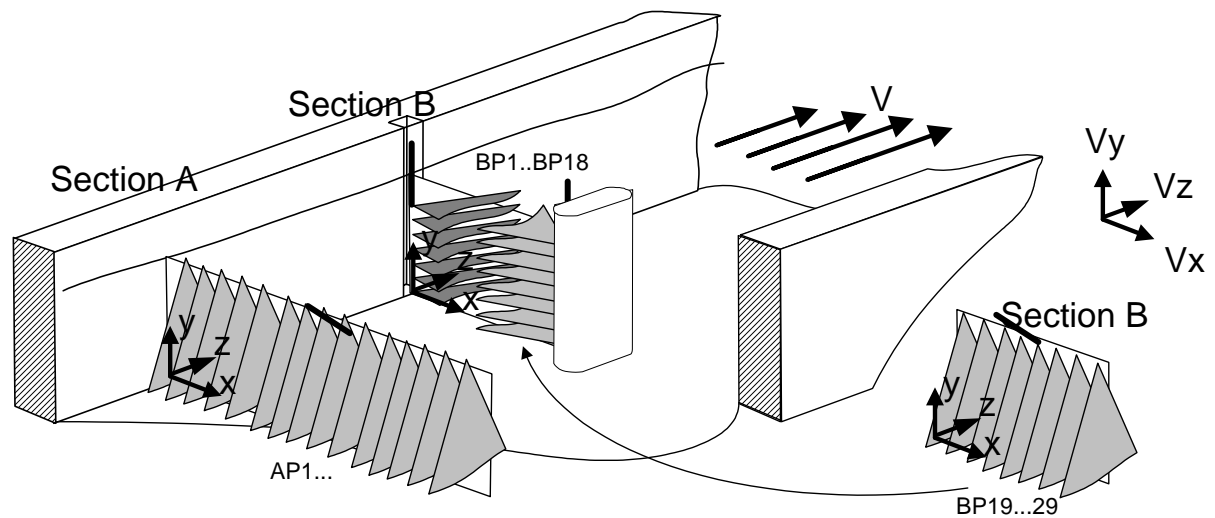

Figure 8. Measuring cross sections and orientation of the acoustic beams of the ADP

3. Flow characteristics

Ahead of the main measuring campaign the flow conditions were checked in order to determine the necessary measuring duration and number of samples to be acquired. To do so, the auto-correlation function had to be evaluated for a series of local measurements with the ADV probe. The auto-correlation function gives not only the standard deviation of the velocity fluctuations but also the micro scale and the macro scale of the turbulent structures in the flow. Figure 9 shows a typical acquired time signal.

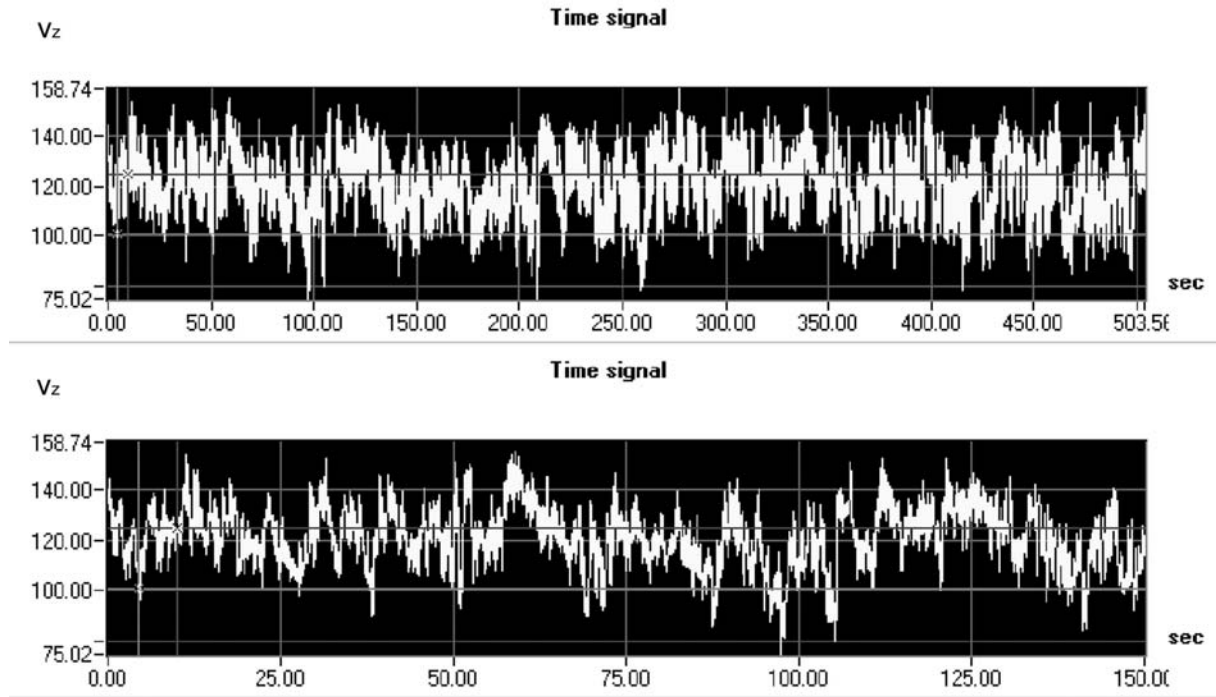

Figure 9. Typical acquired time signal measured with the ADV probe (velocity in cm/s).

The measured standard deviation $\sigma_v = \sqrt{R_{vv}(\tau = 0)}$ of the velocity fluctuations was about 10% of the mean velocity \bar{v} .

Assuming isotropic turbulence the integral time scale, being a measure for the large energy containing turbulent structures, can be calculated from the auto-correlation functions $R_{vv}(\tau)$ as:

$$T_E = \frac{\int_0^{\infty} R_{vv}(\tau) \cdot d\tau}{R_{vv}(\tau = 0)}$$

The macro length scale can be estimated based on the Taylor hypothesis as: $L = \bar{v}_z \cdot T_E$

Evaluation of a series of measurements showed that the macro length scales were between 1.5 and 3 m/s, a value close to the estimation according to Hinze, 1975, for such channel flows.

The micro time scale τ_E is a measure for the smallest turbulent structures in the flow being responsible for energy dissipation. It can be determined from the curvature of the autocorrelation function at $\tau = 0$. Basing again on the Taylor hypothesis of frozen turbulent structures, the micro length scale results to:

$$\lambda = \bar{v} \cdot \tau_E$$

The evaluation of the data showed that the micro length scale is about 0.1 m.

The relative measuring uncertainty of the measured ensemble can be estimated, since the sampling frequency is high in comparison to integral time scale and, therefore, sampling points are not statistically independent, as follows:

$$\varepsilon = \sqrt{\frac{2 \cdot T_{meas}}{n / f_{sampling}}} \cdot \frac{\sigma_v}{\bar{V}}$$

In order to minimize this uncertainty the number of sampling points was chosen to be $n = 3500$. With a sampling frequency of 25 Hz this resulted in a measuring duration of 140 seconds for each probe location.

This means that for each measuring point about 60 large scale turbulent structures were averaged. The small scale structures were resolved with a little more than 2 samples being just at the limit where the structures still can be identified.

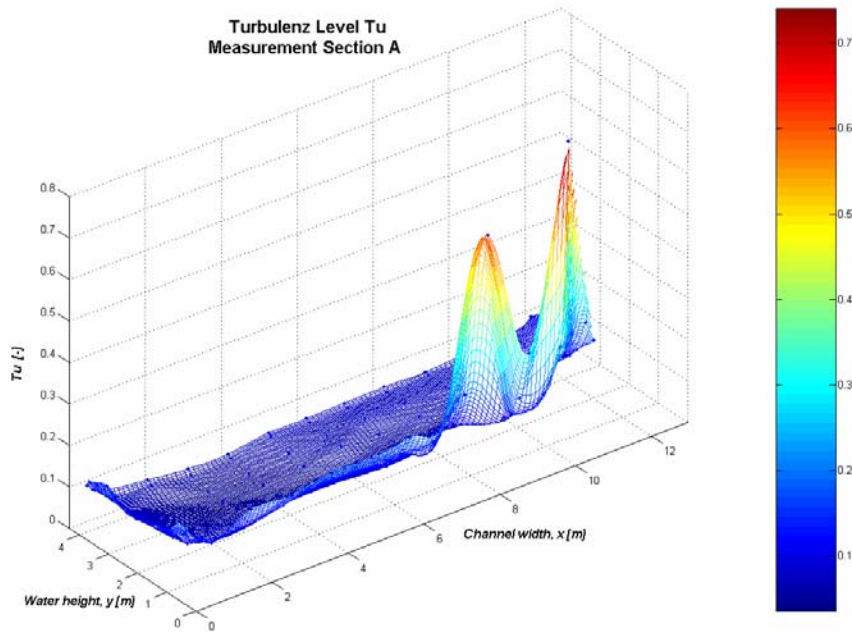

Figure 10. Turbulence level distribution measured with ADV in cross section A

The turbulence level is defined as: $Tu = \frac{\sigma_v}{\bar{V}}$, with σ_v being the standard deviation of the fluctuations of the velocity vector $v(t)$.

The measured turbulence level was of the order of 0.05 in almost the entire cross section A. Close to the walls a higher level of 0.1 was observed. A dramatically increased turbulence level was observed in right bottom corner of the cross section where a sand bank and local backflow occurred.

4. Results

In this paper only results of measurements in cross section A are presented. Figure 11 shows measurements taken with the ADV probe. A typical turbulent velocity profile is observed in the channel, slightly asymmetrical due to the upstream bent. The lower right corner is blocked due the previously mentioned sand bank.

Raw data of the measurement with the acoustic Doppler profiler, ADP, are displayed in Figure 12. Signal reflections from the side and bottom walls lead to unrealistic velocities in these areas.

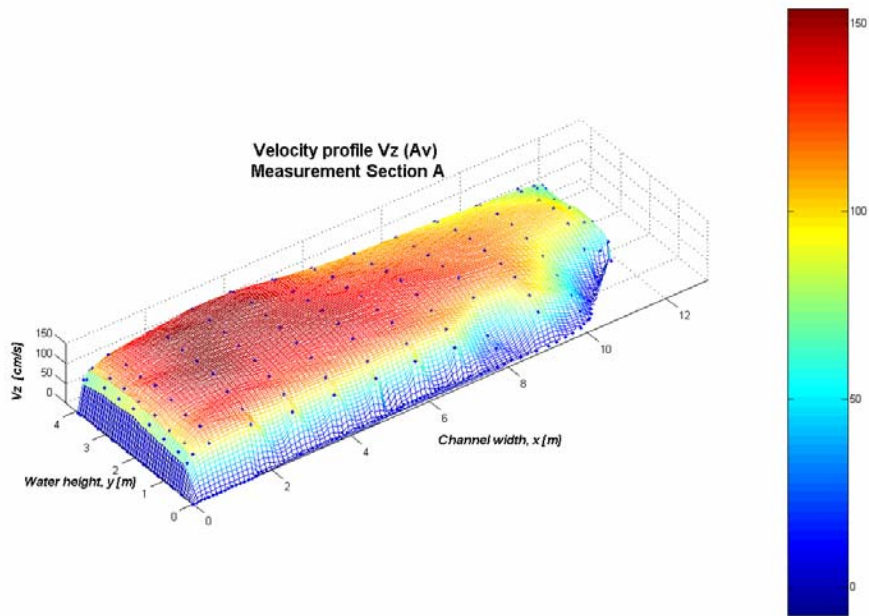

Figure 11. Time averaged distribution of velocity v_z , measured with ADV in cross section A

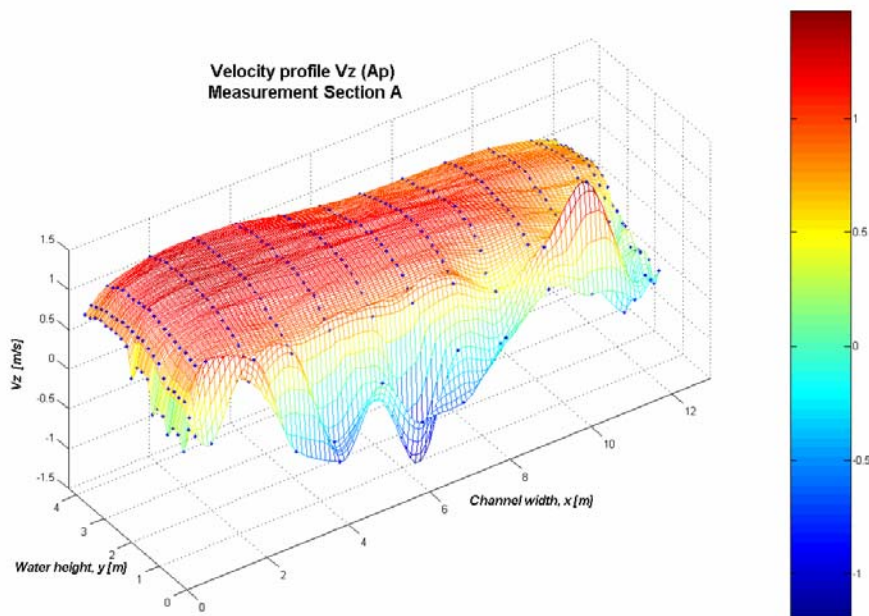

Figure 12. Time averaged distribution of velocity v_z , measured with ADP in cross section A: the data shown in the vicinity of the boundaries are affected by acoustic reflections.

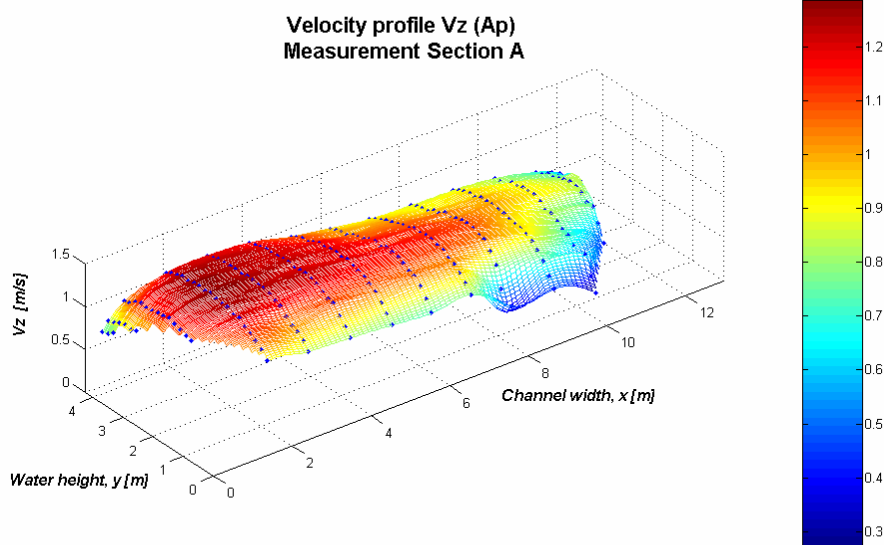

Figure 13. Time averaged distribution of velocity v_z , measured with ADV in cross section A after rejection of data which are outside the specified minimum measuring angle from the boundaries (reflection free zone).

A first trial to compare velocities comparisons lead to considerable discrepancies. However, after recalibration of both, the ADV and ADP, by the manufactures very good agreement was achieved as demonstrated in Figure 14 and 15. In these figures comparisons of two independent ADP measurements (averaged over 180 s) are shown. All these measurements were not taken simultaneously, however head and power fluctuations of the power plant could be kept constant during the entire period within the limit of ± 1 percent.

Vertical distribution are shown for four different positions (from the left wall, looking downstream). The difference between ADP (dashed line) and ADV (full line) is displayed as a dotted line. The smallest differences are generally observed close to the free surface and are of the order of a few percent with changing sign. At the end of the acoustic beam close to the bottom wall of the channel differences rise to a maximum of 10 percent. The overall trend of the velocity distributions is however well reproduced. A measure to judge whether increased uncertainty has to be expected from the ADP measurement is the internally evaluated signal correlation, as displayed in Figure 16. With decreasing signal correlation the probability for erroneous data is increased. The magnitude of the signal correlation depends on water quality, amount and size of particles in the flow, and acoustic reflections.

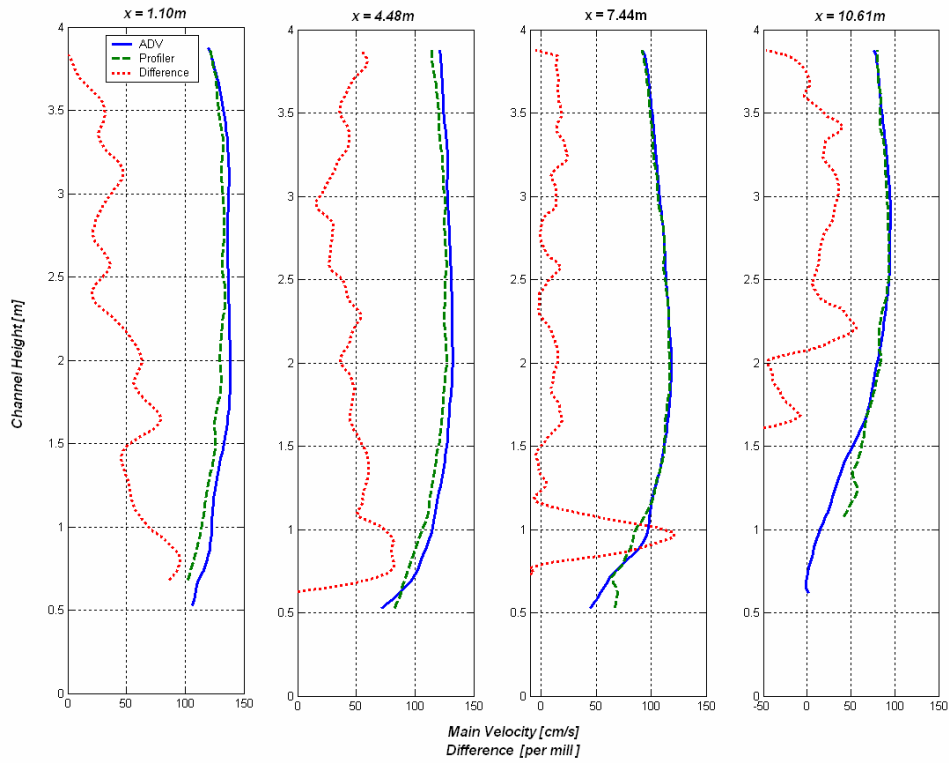

Figure 14. First Measurement: Velocity distributions of the acoustic Doppler profiler (ADP) are displayed with full lines; Velocity distributions of the acoustic Doppler velocimeter (ADV) are displayed with dashed lines; the differences are given with dotted lines.

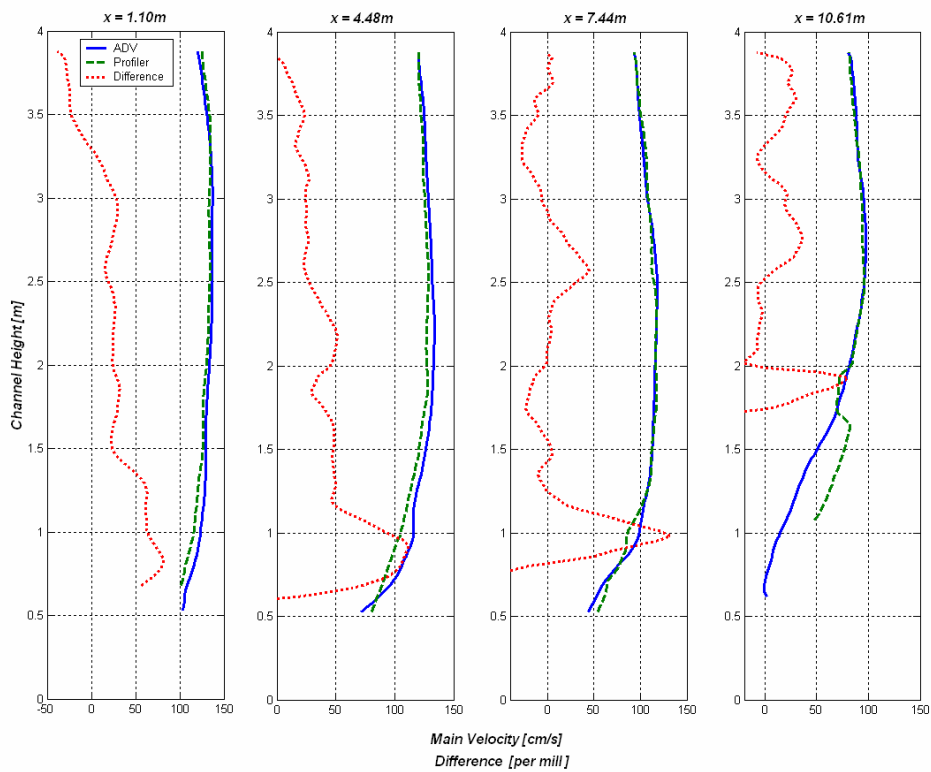

Figure 15. Second Measurement: Velocity distributions of the acoustic Doppler profiler (ADP) are displayed with solid lines; Velocity distributions of the acoustic Doppler velocimeter (ADV) are displayed with dashed lines; the differences are given with dotted lines.

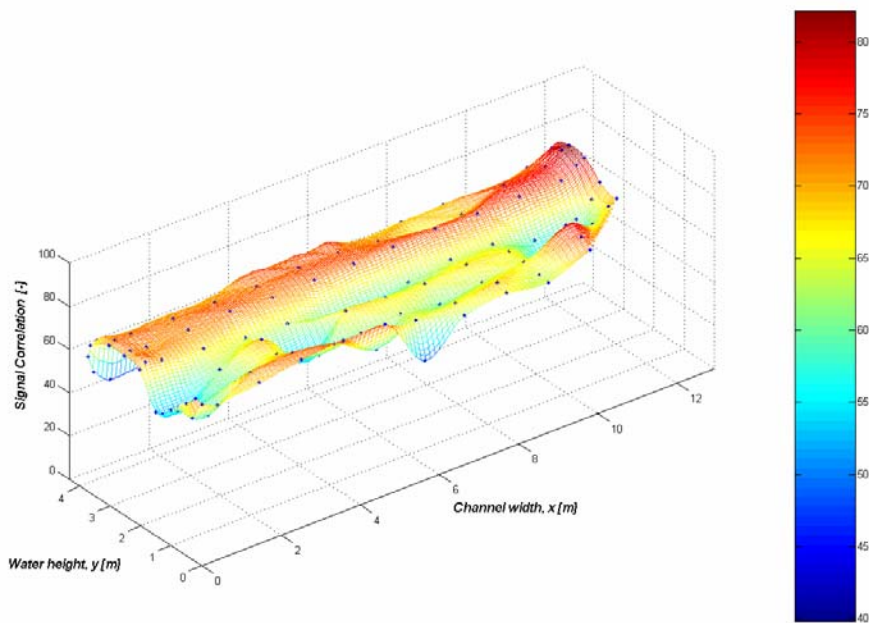

Figure 16. Signal correlation

5. Conclusions

Traversing a measuring cross section with a velocity probe is very time consuming. The advantage of an acoustic Doppler profiler (ADP) is that velocity distributions may be acquired with little installation effort and within short time periods. The performed comparative measurements with an acoustic Doppler velocimeter (ADV) and the ADP demonstrate that the ADP allows to measure easily and with good accuracy velocity distributions in large cross sections. Quantitative comparison showed good agreement of the results if an acceptable signal correlation is achieved and if erroneous data due to reflected acoustic signals are rejected.

Acknowledgement

This study was made possible by a grant of the Swiss national energy foundation and the support of Centralschweizerische Kraftwerke.

References

- Voser A., Analyse und Fehleroptimierung der mehrpfadigen akustischen Durchflussmessung in Wasserkraftwerken, Dissertation ETH Nr. 13102, 1999.
- Staubli T., Flow field upstream of a trash rack measured with an acoustic Doppler probe, Proc. IGHEM Kempten, 2000
- Gordon L., Nylund S., Lohrmann A., Test Results with the EasyQ RIVER Flow Sensor, ASCE, 2001
- Lemon D.D., Cartier W.W., Measuring Hydraulic Turbine Discharge with Acoustic Scintillation Flowmeter, Proc. IGHEM Montreal, 1996
- Hinze J.O., Turbulence, Mac Graw Hill, 1975